

DH100F

Commercial battery cabinet

The DH100F is an AC-coupled battery cabinet for commercial and industrial energy storage. The all-in-one solution provides storage capacity of 71kWh, 86kWh or 100kWh with an integrated power conversion system (PCS) of 36kW, 43kW and 50kW respectively. It offers direct PV connection thanks to an optional MPPT module.

- + + All-in-one integrated solution
- + + Off-grid operation
- + + Integrated PCS
- + + Optional direct PV connection
- + + 6000 cycles*
- + + Integrated PCS
- + + Parallel connection up to 8 cabinets (800kWh)
- + + Integrated fire extinguishing system



General characteristics

Dimensions (WxHxD)	1200x 1048 x 2258 mm
Net Weight	1610kg (to be confirmed)
Battery type	LFP (LiFePO ₄)
Max. site altitude	3000m (derating above 2000m)
IP-protection class	IP55
Anti-corrosion	C3
Cooling principle	Air cooling
Warranty	5 jaar **
Display	Touchscreen
Communication interfaces	Ethernet/4G/RS485
Cycle life	6000 cycli / 80% EOL (25°C, 100% DOD, 0,5P)
Fire extinguishing system	Level 3 detection + system level fire protection
Standards	GB/T36276, GB/T34131, IEC62619, IEC63056, IEC60730, EN62477, EN61000-6-2/4, IEC 62933
Operating temperature range	-20°C to +50°C
Relative humidity range	0% to 95%



Battery technical specifications

Model	DH100F-71kWh	DH100F-86kWh	DH100F-100kWh
System capacity (kWh)	71	86	100
Cell capacity (Ah)	280	280	280
Module configuration	1P16S	1P16S	1P16S
Battery packs	5 per cabinet	6 per cabinet	7 per cabinet

AC output (on-grid/ off-grid)

Rated output power (kW)	35	40	50
Max. AC current (A)	60	74	86
Rated output voltage (Vac)	400	400	400
Voltage range (Vac)	320-460	320-460	320-460
Wiring method	3P4L+PE	3P4L+PE	3F+N+PE
Rated frequency (Hz)	50/60	50/60	50/60
Grid frequency range (Hz)	45-55 / 55-65	45-55 / 55-65	45-55 / 55 - 65
THDI (on-grid)	<= 5%	<= 5%	<= 5%
Switch time (off-grid) (S)	<2	<2	<2

PV input characteristics (optional MPPT modules)

Max. input power (kW)	25/50	30/60	35/70
Max. AC current (A)	80/160	80/160	80/160
Max. short circuit current (A)	100/200	100/200	100/200
Max. voltage (V)	1000	1000	10000
Start-up voltage (V)	310	370	430
MPPT voltage range (V)	300-1000	300-1000	300-1000
MPPT tracker per MPPT module	1	1	1

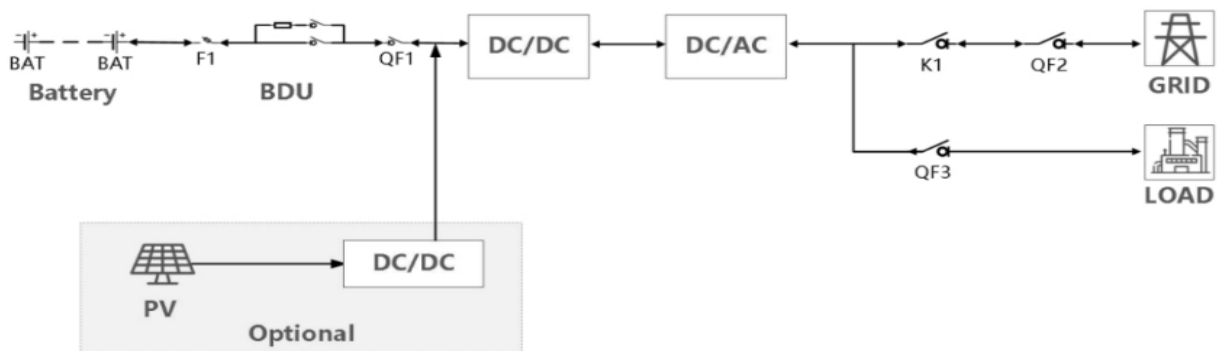

*Measured at 25C, 100% DOD with 1h between the cycles.

** Please refer to the warranty document for detailed scope of the 5 years warranty.

The specifications contained in this datasheet may deviate slightly from our actual products due to on-going product improvement and are subject to change at any time without prior notice.