

Flow

Symmetrical series

Autarco's Flow mounting system has been designed keeping an ease of installation in mind. It provides a sophisticated yet simple, quick but proper installation. Suitably designed for new generation of larger solar panels, it is ideal for large or small installations. Thanks to its smart and stable construction, it allows for ultra-fast assemblies whilst ensuring the solar panels are safely supported.

- + 15-year product warranty
- + Landscape orientation
- + One tool required for installation
- + Install up till 5 degree surface inclination
- + Suitable for situations with high wind and snow loads
- + Automatic potential equalisation (NEN1010)
- + Linked fields up to 50 metres possible
- + Pre-assembled components with fewer packaging materials

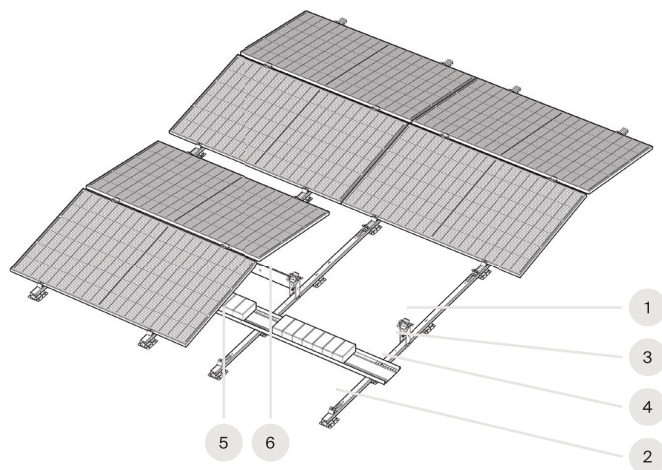

Rest panel on mounting and easily access clamps



Easy to set up in perpendicular orientation



Integrated cable management

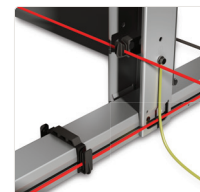

Fastenings

	1 Top clamp	M3.FTC
	2 Bottom clamp	M3.FBC
	Short screw	M3.MSS

System components

	3 Base assembly (with connector)	M3.FBS-2300/2460/2785
	4 Ballast plate	M3.FBP-1508
	5 Ballast connector	M3.FBC-1130
	6 Connector plate	M3.FCP-750/1050

Optional components

	Sizing tool	M3.FST-1560
--	-------------	-------------

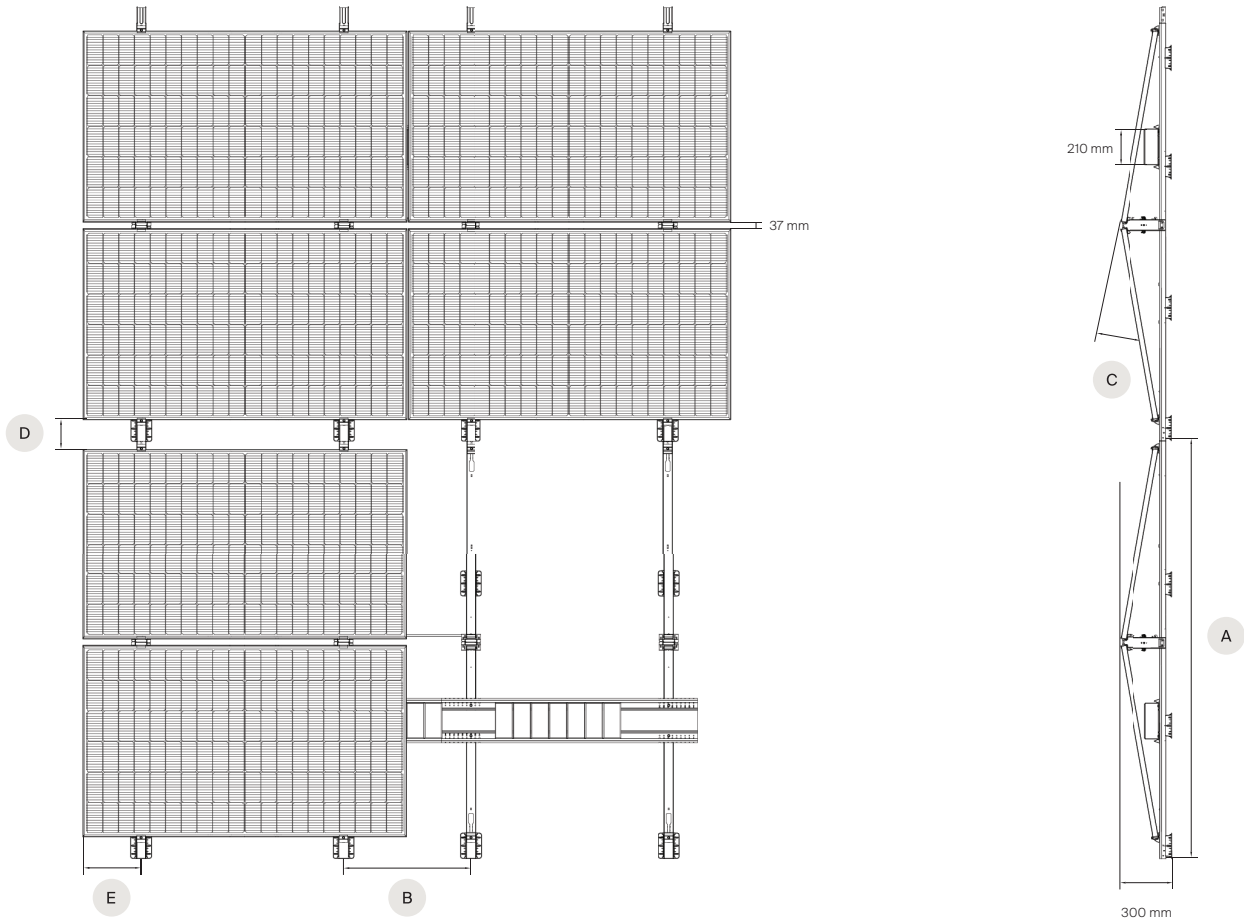

Autarco panel series	##H series	##L series	##M series	##N series	##Q series
No. of Cells/Wafer size	72/166	60/182	66/182	72/182	78/182
Panel type	MHH	MHL, TBL, TGL	MHM	MHN, TBN	TNQ
A Base assembly	M3.FBS-2300	M3.FBS-2460	M3.FBS-2460	M3.FBS-2460	M3.FBS-2460
B Connector plate	M3.FCP-750	M3.FCP-750	M3.FCP-750	M3.FCP-1050	M3.FCP-1050
C Module angle	11°	10°	10°	10°	10°
D Walkway (mm)	213	179	179	179	179
E Clamp position (mm)	360	364	360	514	520
Panel length (mm)	2094	1903	2094	2278	2465
Panel width (mm)	1038	1134	1134	1134	1134
Mechanical Load	5400 Pa (front) / 2400 Pa (back)				
Material	Magnelis®, aluminium, stainless steel				
Suitable rooftypes	Flat roofs (Bitumen, PVC, EPDM, TPO); Up to 5 degree surface inclination				

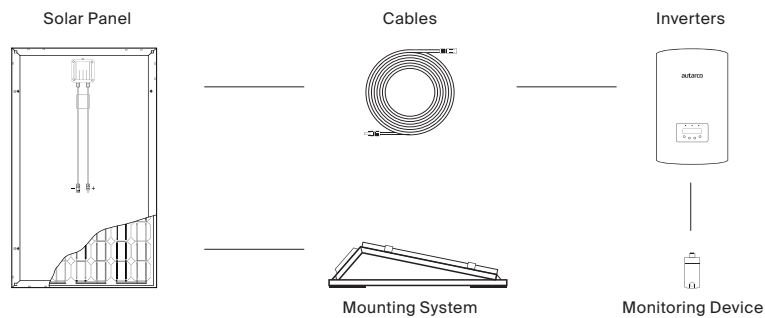

The specifications contained in this datasheet may deviate slightly from our actual products due to on-going product improvement and are subject to change at any time without prior notice.